

# Stainless Steel Bumper

## INSTALLATION INSTRUCTIONS

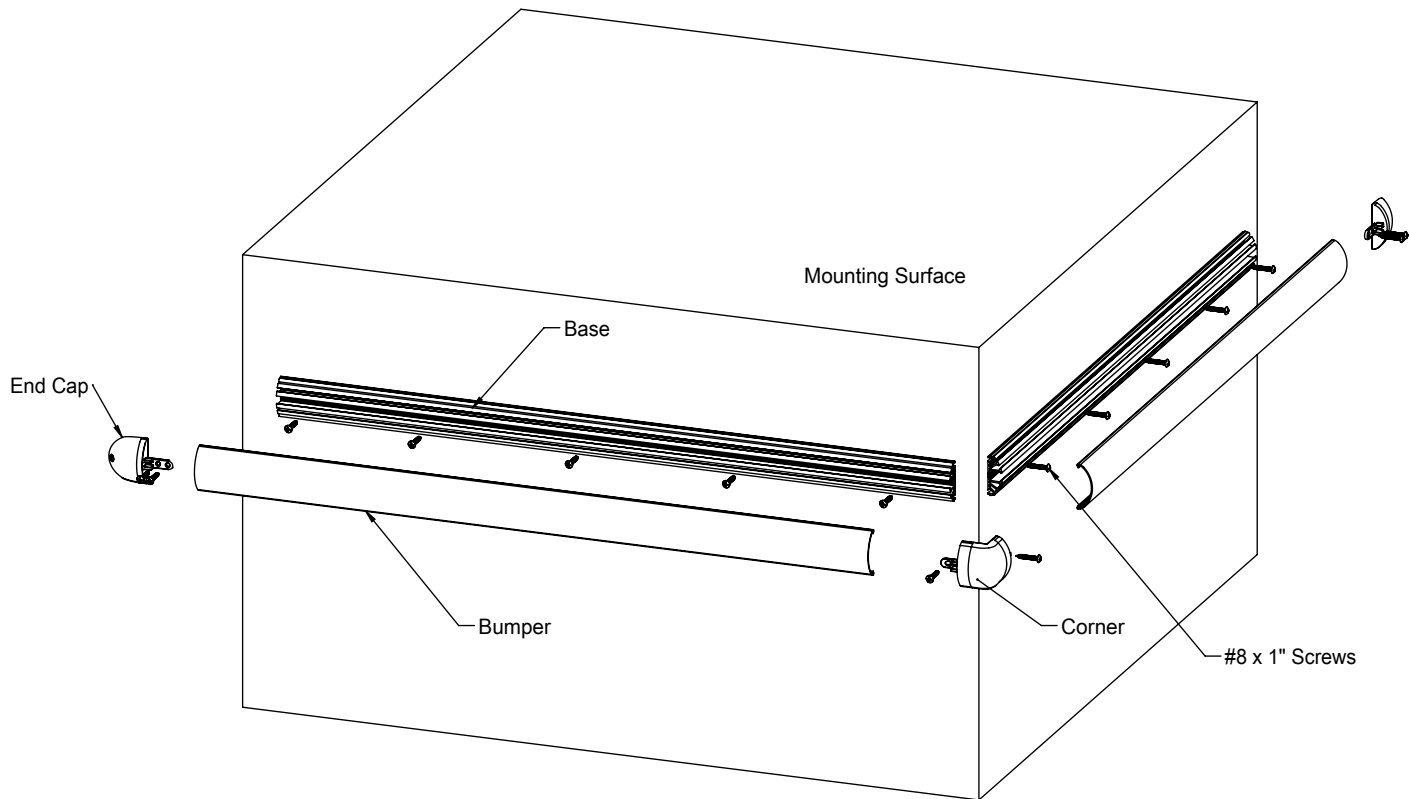

## Tools Required

- Pencil/Marker/Chalk line
- Tape Measure
- Drill + Phillips Driver Bit
- Rubber Mallet
- Cotton Rags
- Straight Edge
- Level
- Mild, non-abrasive cleaner or stainless steel polish
- Circular Saw—capable of cutting metal, low RPM, dry-cut
- Circular Saw Blade—designed to cut stainless steel; thin or ultra-thin kerf; high tooth count (76T-100T); non-abrasive; tungsten carbide-tipped or cermet-tipped blade



**McCue Corporation**  
Peabody, Massachusetts, USA  
+1 (800) 800 8503  
customercare@mccue.com

**McCue UK & Europe**  
Milton Keynes, United Kingdom  
+44 (0) 1908 365 511  
uksales@mccue.com

**McCue Asia**  
迈客(厦门)有限公司  
Xiamen, Fujian, China  
+86 592 2200790

**mccue.com**





1

Using a tape measure and chalk line (or pencil), mark a line on the case indicating placement of the top edge of bumper according to your height specification.

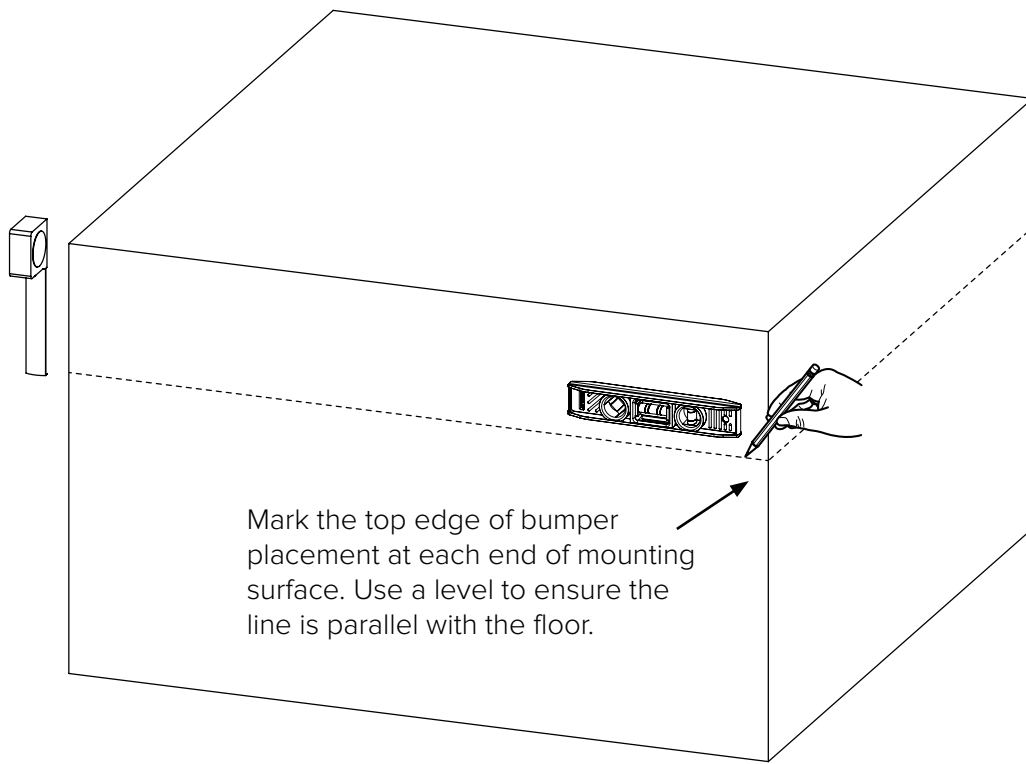

2

Measure case to determine base length. Allow an offset of  $1\frac{3}{4}$ " for end caps and  $1\frac{1}{8}$ " for corners.

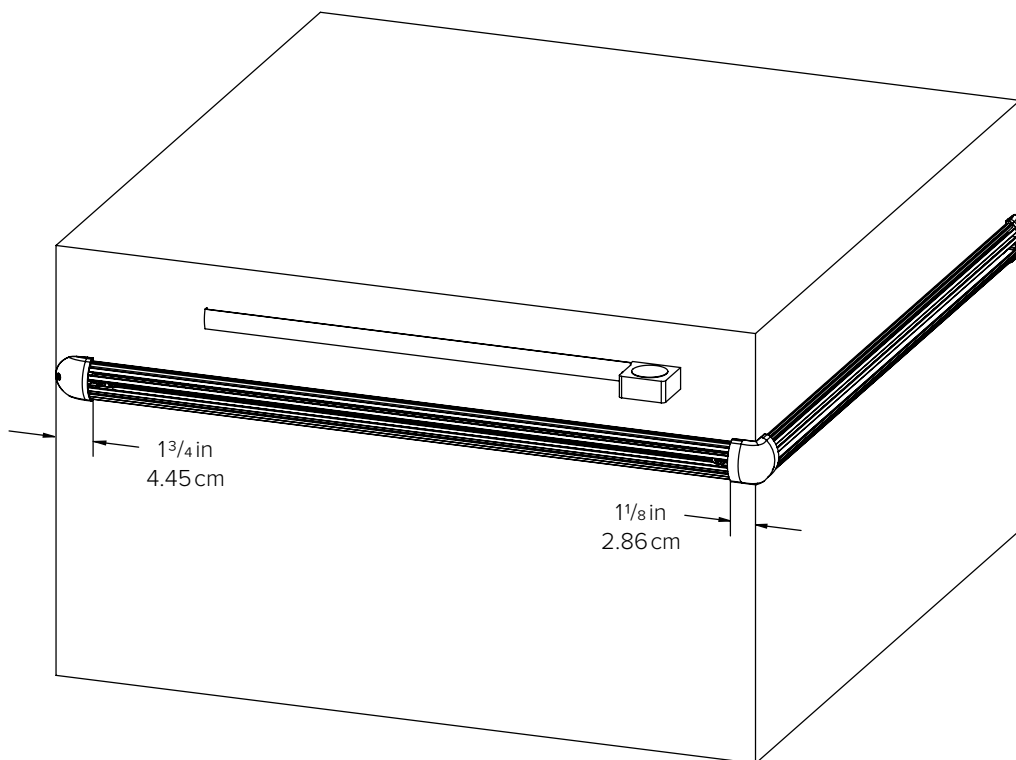



- 3** Use a circular saw to cut base to length.

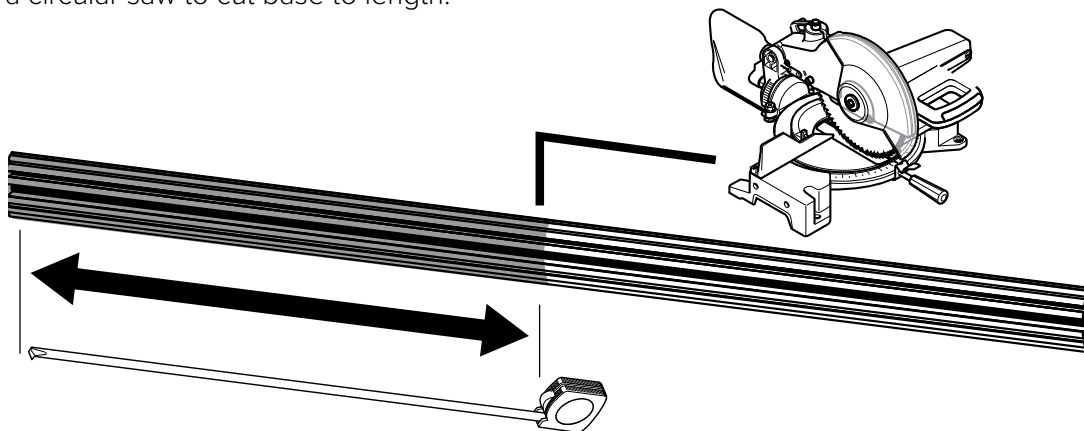

- 4** Holding the ends and corners, align base to verify cut lengths before attaching to case. First affix corners, using recommended screws. Then, smooth bumper base against surface and affix end pieces.

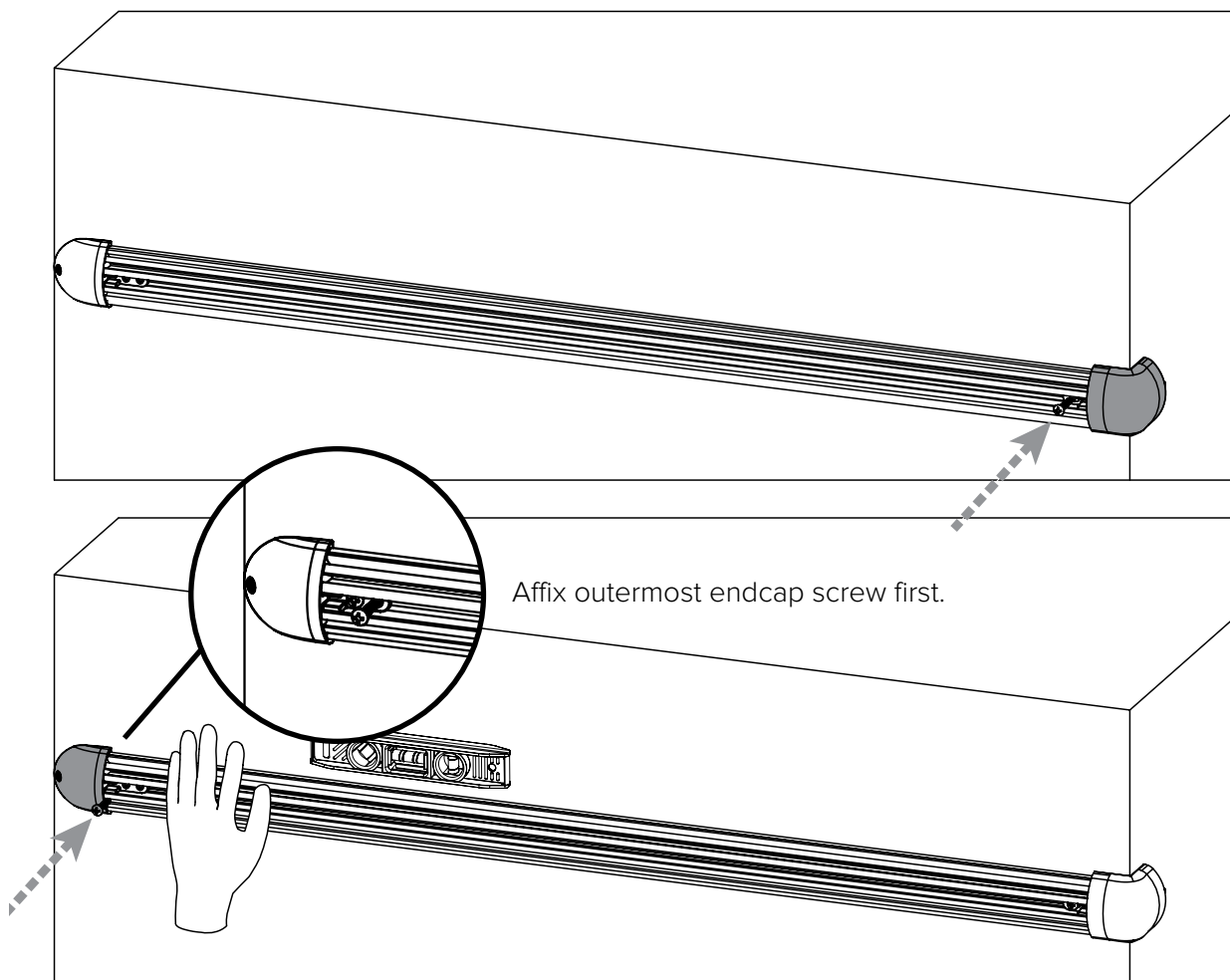



5

Affix remaining length of base with screws placed approximately every 6 inches.

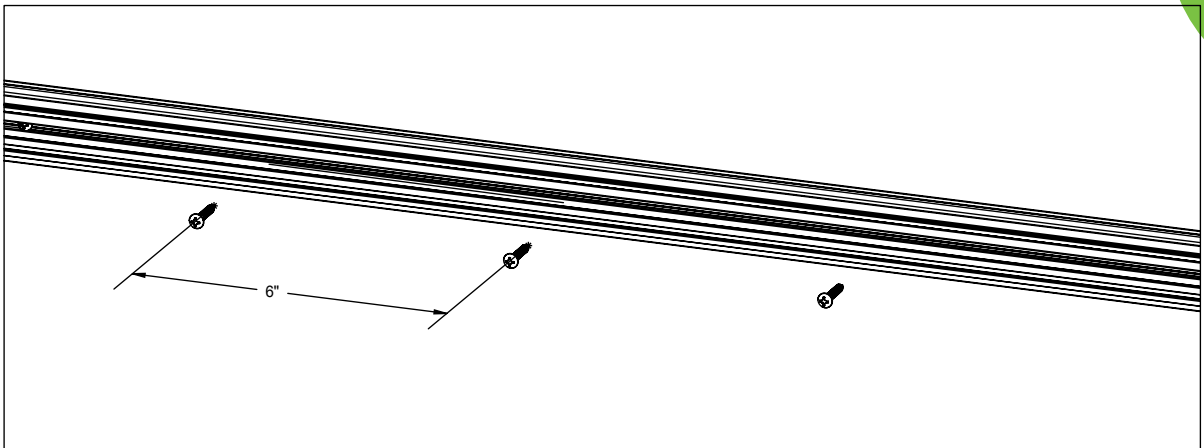

6

With ends, corners and base installed, measure along the base from inside edges of ends and corners, to determine length of stainless top.

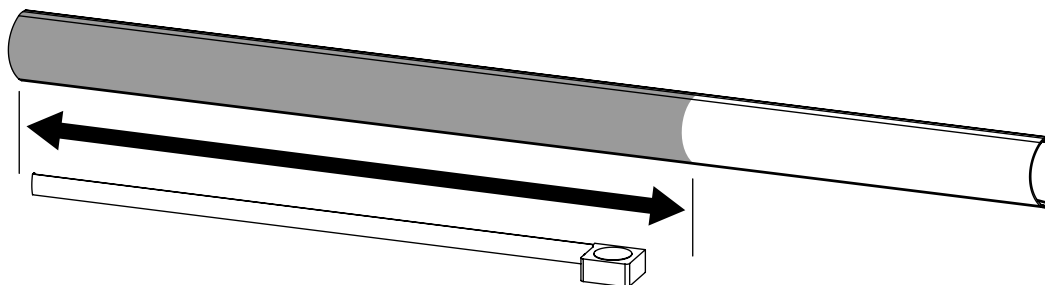
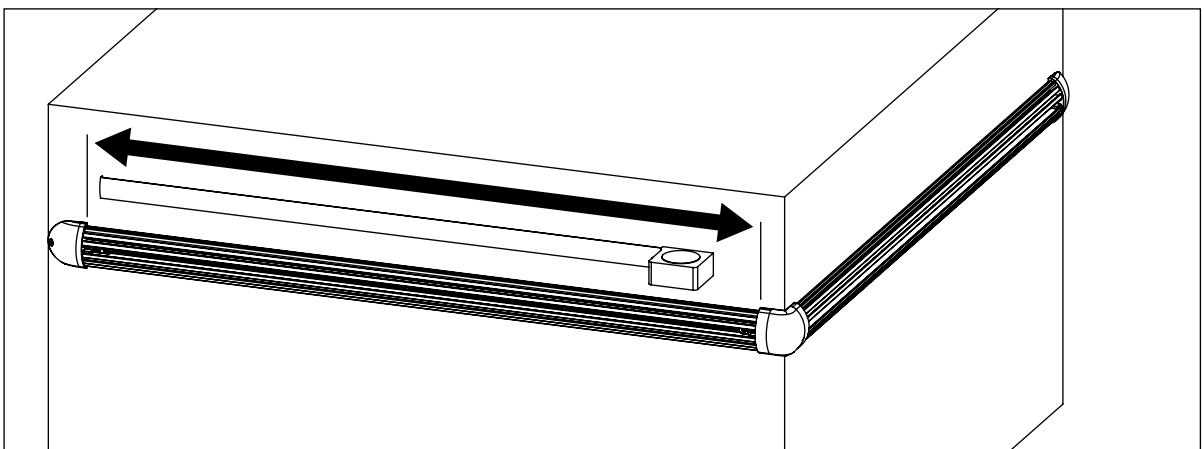



7

Secure stainless top in place with clamps prior to cutting. Using a circular saw with stainless steel cutting blade, cut top to length and file ends to remove burrs, if necessary. Lower saw gently onto bumper—do not force, allowing saw blade to do the work.

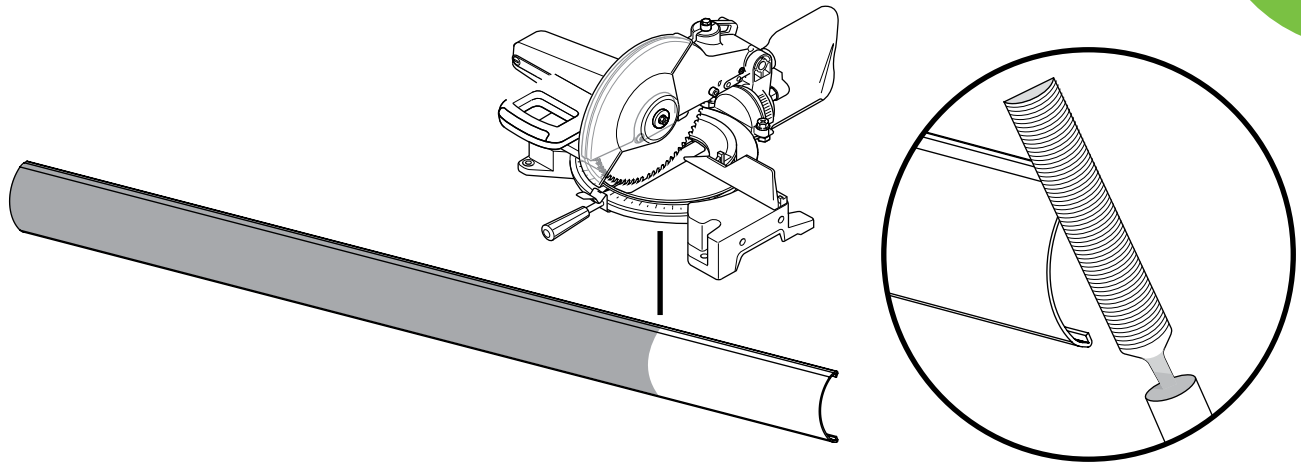

**CAUTION:** Over-tightening clamps can distort bumper profile



**CAUTION:** Blade and bumper top will be hot after cutting

## Recommended Specifications:

- Metal cutoff saw and blade with a thin-gauge, stainless steel application specification
- Kerf: thin to ultra-thin
- Example: Makita LC 1230 + A-90847 12" 78T C.T. Dry Cut Stainless Steel blade
- Cermet blade, tungsten-carbide tips
- High tooth count: 76T–100T
- Saw speed: 1500 RPM - 2000 RPM
- Non-abrasive blade will prevent burning

8

Install bumper top onto base by pressing upper half to snap over base latching feature. Using a soft mallet or deadblow hammer and cloth, apply pressure to the bottom half of bumper to pivot and snap into place. Continue along length of bumper top until completely installed.

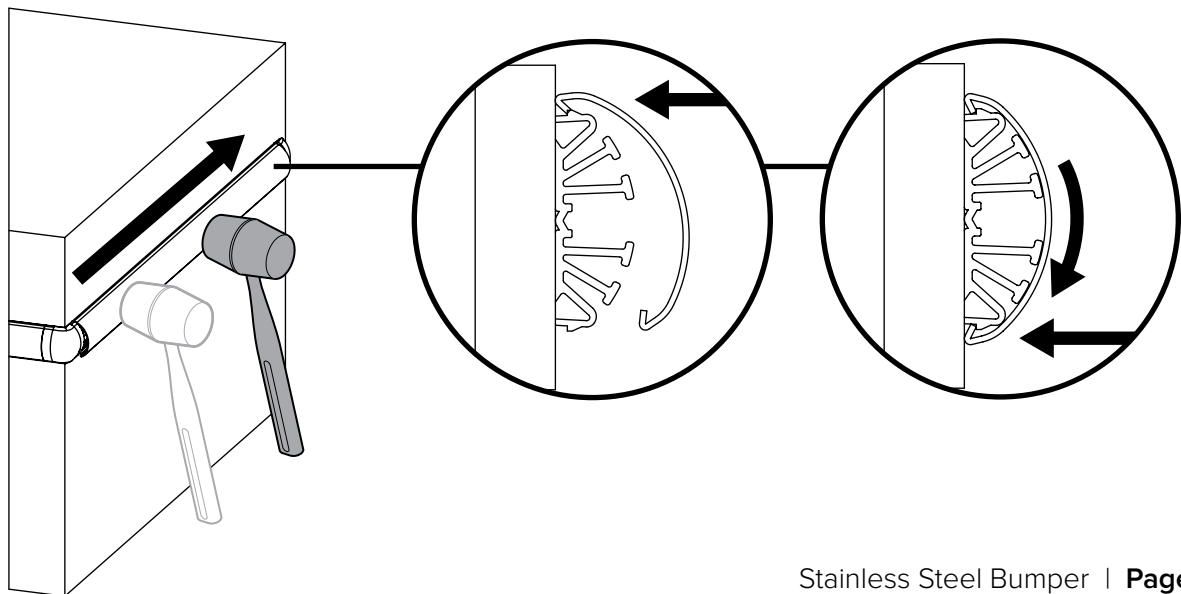



9

Once installed, peel back protective film and clean the stainless top using a soft, non-abrasive cloth. See cleaning instructions (separate document) for more details.

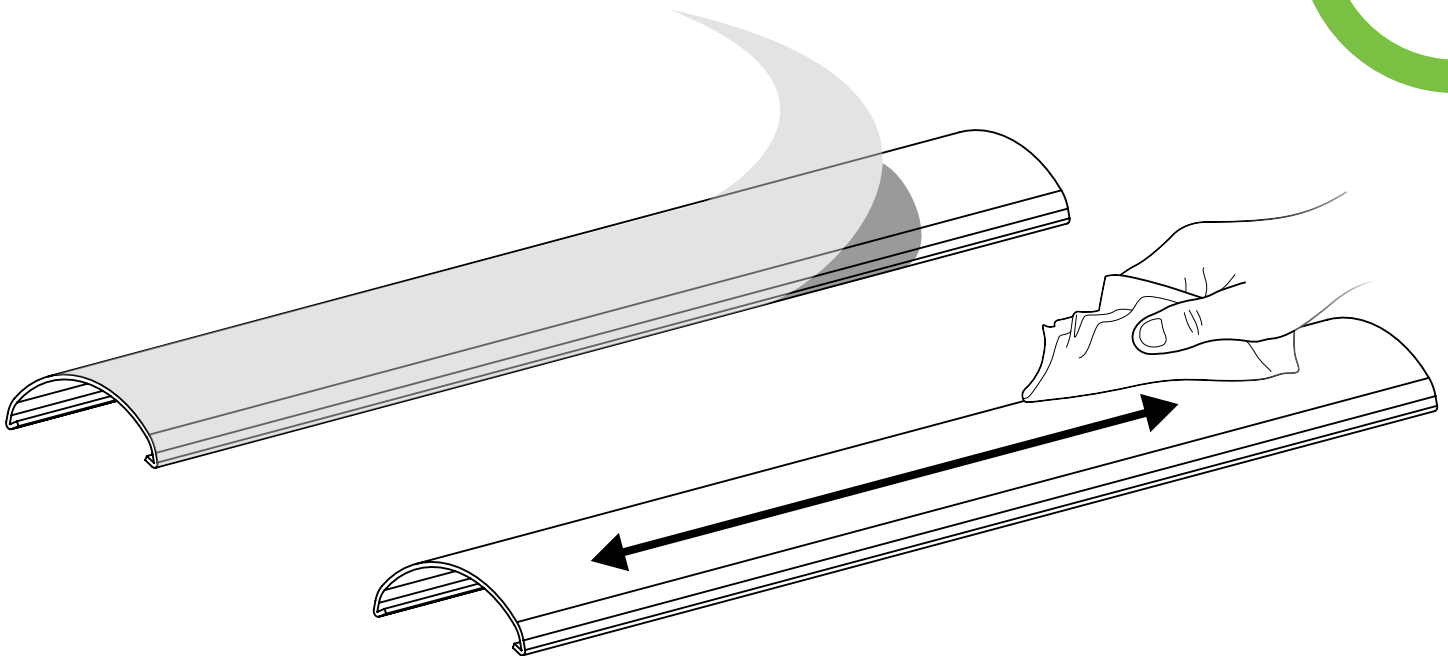

10

### To Remove Bumper

Stainless top can be removed from base with a prying motion. Insert a thin, rigid tool between bumper top hook and mounting surface/wall. Press straight in on internal leg feature to disengage snap. Pivot pry tool to release top from base snap feature.

