

# CartGuard® Flexible Bumper Installation Instructions

## CartGuard 1 & CartGuard 2 Flex

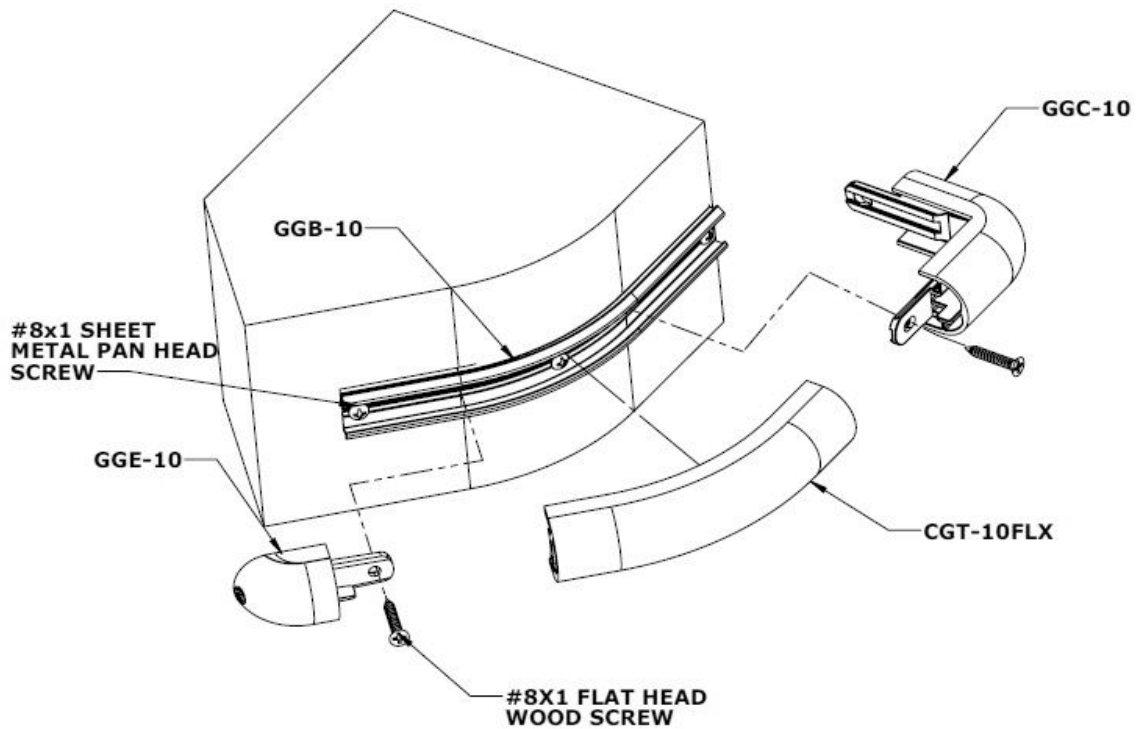

### Tools Required:

- Tape measure
- Pencil
- Drill with Philips driver bit
- Rubber mallet
- Straight edge
- Chalk line
- PVC cutters
- Cotton rags
- Non abrasive cleaner

### Important:

Bumper must be stored at room temperature for at least 24 hours before installing.

**If your bumper has a protective film on it, DO NOT** remove the protective film from the bumper until the final step.

**DO NOT** miter bumper to create corners.

**DO NOT** install end caps or corners unless there is a screw ¼" from the end of the base.

## Step 1: Mark the Case

Use a tape measure and chalk line (or pencil) to mark a line on the case where the top of the bumper will be placed (based on your bumper height specification).

## Step 2: Cutting the Base

### Cutting the Base for Corners

When using corners, use a mitre saw to cut the base so that it is flush with the corner of the mounting surface (Figure A.) The base cannot overlap at the corner.

### Cutting the Base for End Caps:

When using end caps, cut the base short of the edge of the mounting surface to equal the "X" measurement according to the appropriate bumper profile type (Figure B.)

CartGuard Flex 1"	X = 5/8"
CartGuard Flex 2"	X = 7/8"

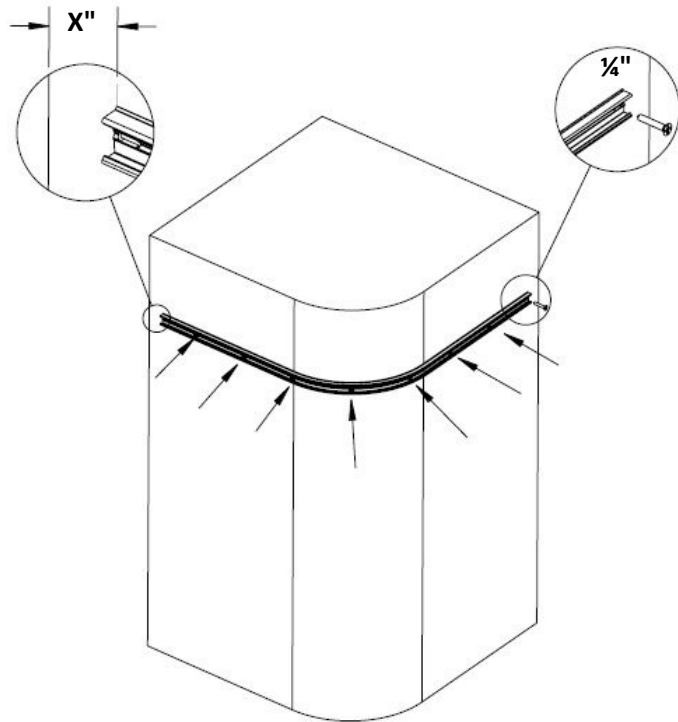
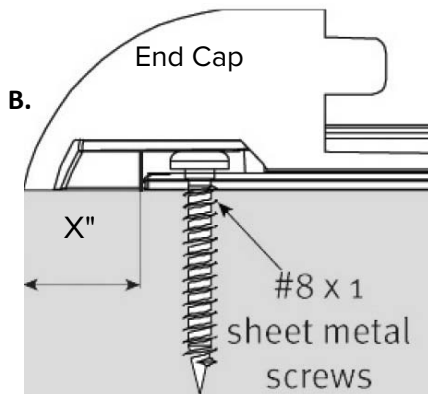
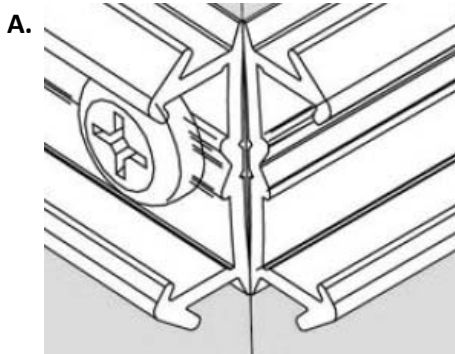

## IMPORTANT: DEAD STOP APPLICATION

Dead stops should only be used when the edge of the case ends against a wall, another surface or another dead stop. When a dead stop must be used, do not place a screw 1/4" from the end of base. Instead, cut the base 1/4" short of the desired dead stop location. See Dead Stop Installation.

### Step 3: Installing the Base

Line up the top of the base with the penciled line on the case. Using a drill with a Phillips driver bit, attach the base to the mounting surface by placing #8 x 1 sheet metal screws in the screw guide holes (Figure A.) every 4 inches (Figure B.) Do not over tighten screws.

**Important:** a screw should be placed into the base  $\frac{1}{4}$ " away from the end of mounting surface (Figure C.)

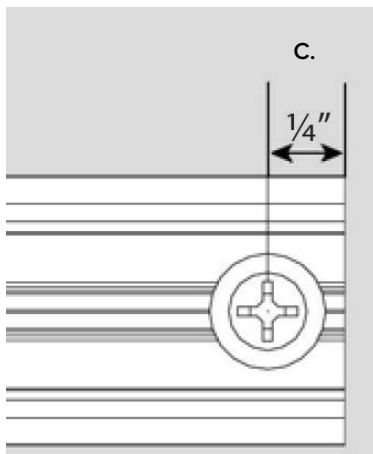
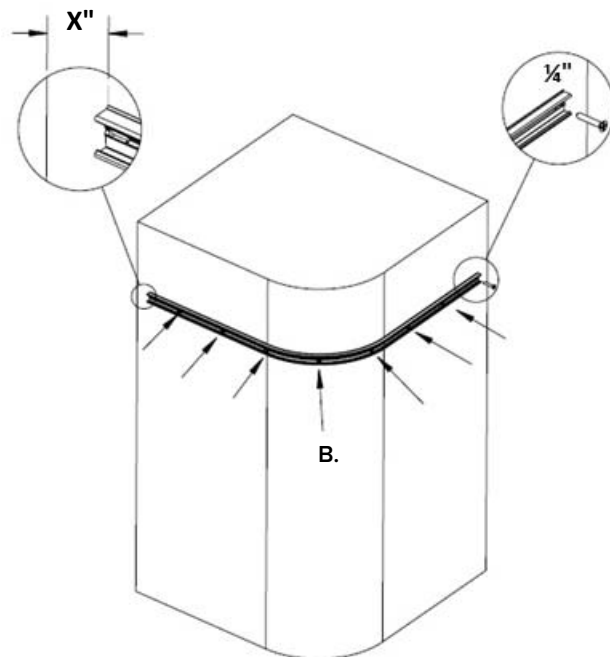
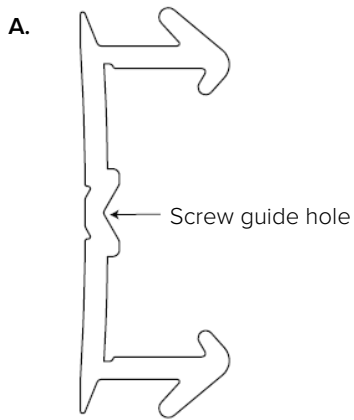

## Step 4: Installing Corners

Corners have screw recesses which accommodate the screw that is positioned  $\frac{1}{4}$ " from the ends of the base (Figure A.)

The corners have hooks that must snap into the hooks on the base to perform correctly (Figure B.)

Snap one side of the corner onto the base. (Figure C.)

Slide the other side of the corner onto the base (Figure D.) and use a mallet covered with a cloth to engage the hooks and snap that side onto the base (Figure E.)

Screw the corner to the mounting surface using #8 x 1 wood screws (Figure F.) Be sure that the screws hold the corner tightly against the mounting surface.

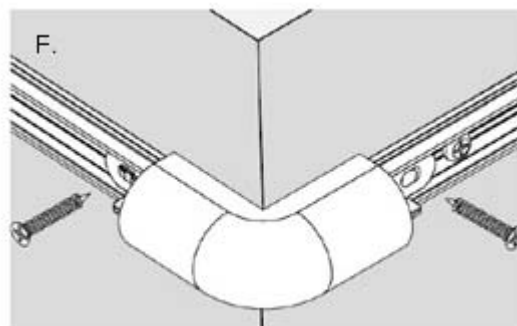
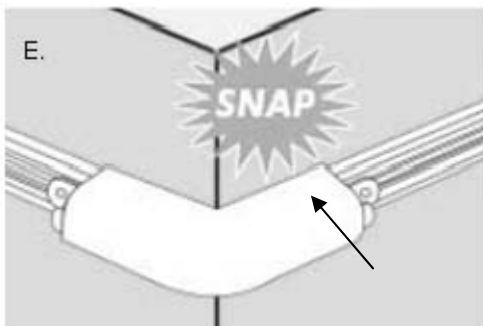
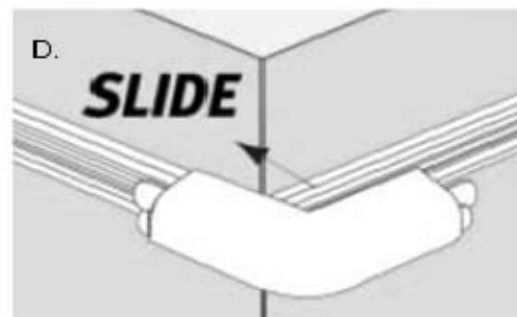
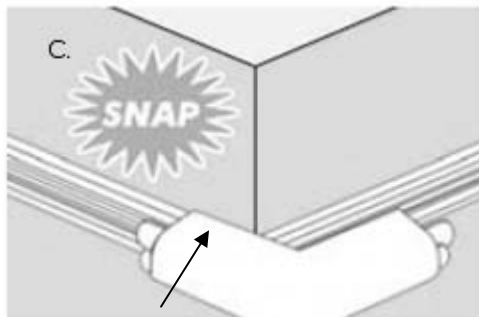
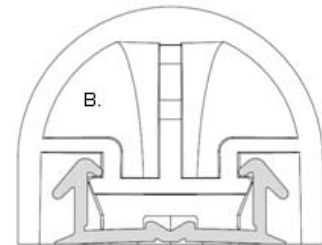
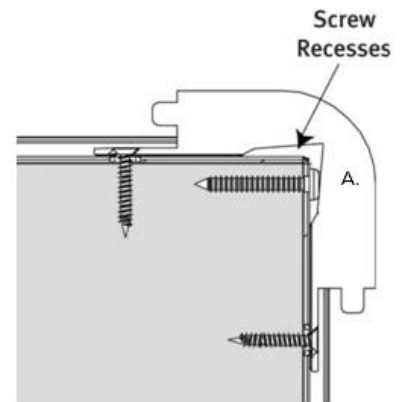

### Step 5: Installing End Caps

End caps have hooks which must engage with the base to perform correctly (Figure A.)

End caps have screw recesses which accommodate the screw placed  $\frac{1}{4}$ " from ends of base (Figure B.)

Screw end caps to the mounting surface using #8 x 1 wood screws (Figure C.)

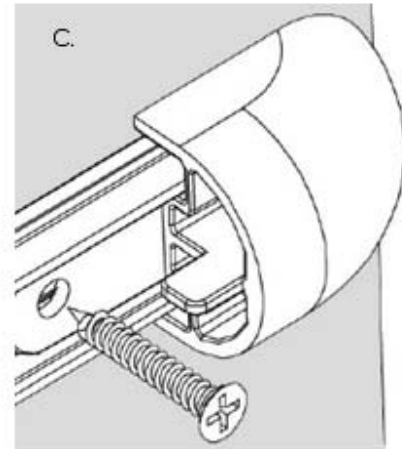
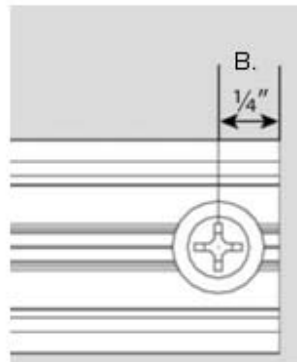
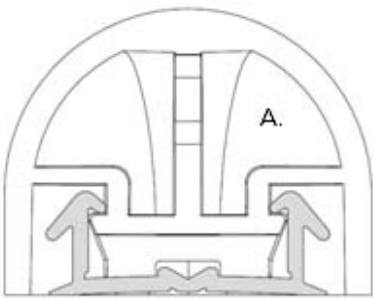

### Step 6: Installing Dead Stops

Important: Dead stops should only be used when the edge of the case ends against a wall, another surface or another dead stop.

Slide the dead stop flush with the cut end of base.

Secure dead stop with #8 x 1 wood screw.

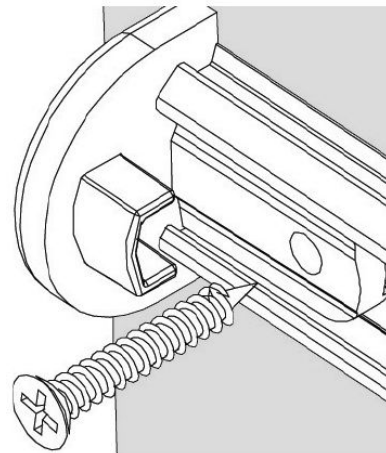

## Step 7: Installing the Flex Top

Place one end of the flexible bumper top so that it fits flush against one end cap.

Attach the top edge of the flex top to the top tracks of the base by pressing it onto the base from the end cap to the opposite end of the base.

Note: There will be excess flex top at the opposite end.

Next, snap the bottom edge of the flex top onto the bottom tracks of the base.

To ensure proper fit, pound the flex top onto the base using your hand or a rubber mallet. Cover the mallet with a cloth to prevent marring the flex top.

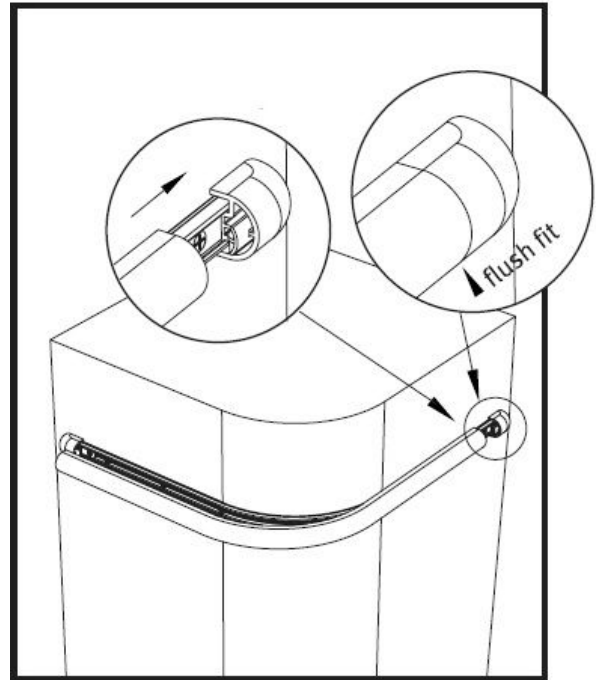

## Step 8: Fitting the Flex Top onto the Other End Cap

Making sure that the starting edge of the flex top is sitting flush against one end cap, place the flex top along the length of the base and mark your cutting length according to the following:

For bumper lengths up to 4', cut the flex top  $\frac{1}{4}$ " longer than the inner edge of the end cap.

For bumper lengths longer than 4', cut the flex top  $\frac{1}{2}$ " longer than the end cap for every 4' of bumper length.

**Important:** Do not stretch the flex top. When cutting the flex top, make sure that the cut is straight so that it fits squarely with the end cap.

After the flex top is cut, retract the end slightly and feed it into the end cap. Be sure to also press the flex top onto the tracks of the base.

You should feel and hear the bumper snap into place for a snug fit.

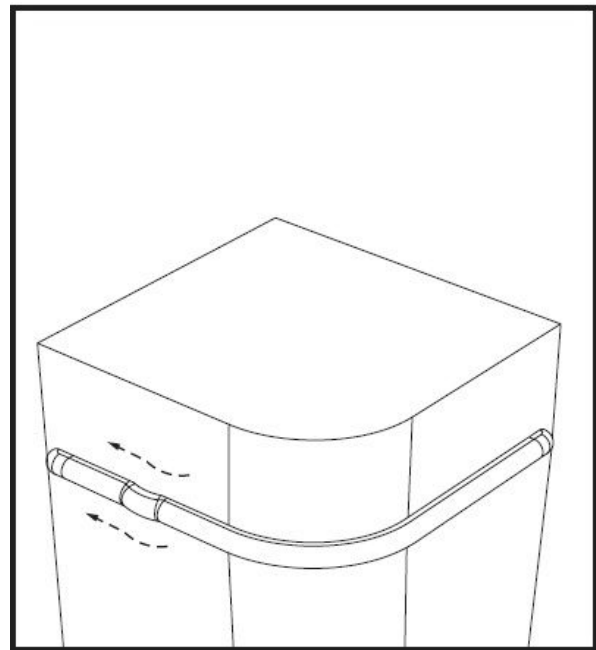

### **Step 9: Checking Fit and Finishing**

To ensure that the bumper is properly attached along the entire length of the wall or fixture, be sure that the bumper is smooth and not bent or buckled in any area and that each end fits flush with the end cap.

Clean any dust or debris with a cloth and non abrasive cleaner.

Installation is complete.

